

Üj'k Y Q) ^ d' i i e e a a' a j a a' e e f			
S' ) a ^			
 Elektronische Bausätze		Ü d i P a j ) ^ * A j & @ a (	Ü d i ^
		Ü d i ) a ^	Ü d i ^ B i E F G
Ü ^ j ^ a a i c		Ü a a' d i G i	

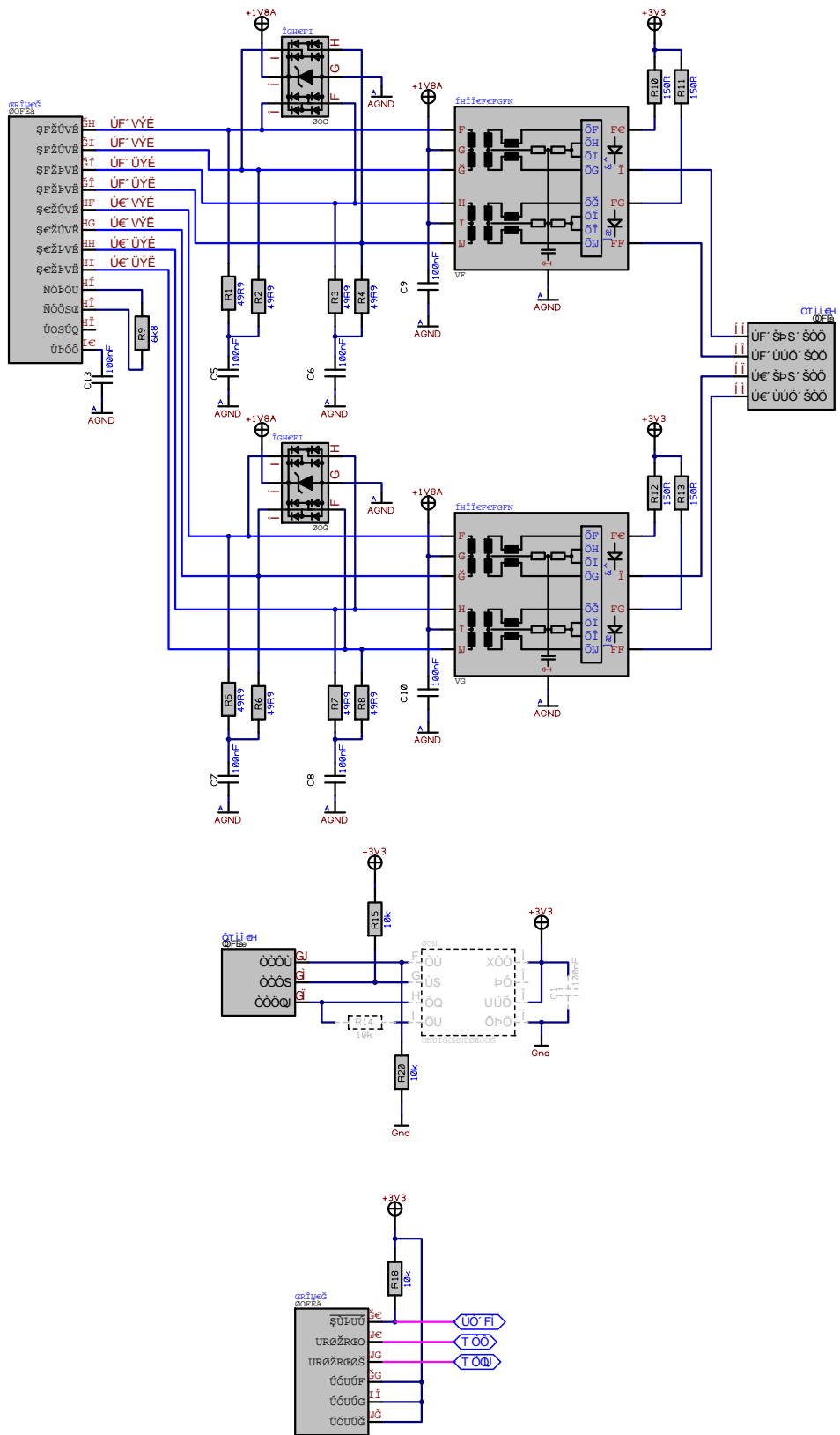

Uj'enc  
Y Q) ^ d' y i i e e a a' a' a' e e f

S' ) a ^

**eHaJo**  
Elektronische Bausätze

DE d:  
P a j ) ^ \* A & @ a {

U' a' ) ) a e ^  
O c @ ) ^ c

U' a' e } \* B > E  
FG

O: a: ^

O' a' ) ^ a @ a c

U' a' e  
H d )  
i

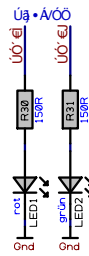
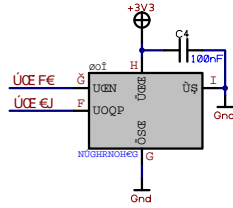

Uj 10c Y Q) ^ d Y i i e e a a ^ a j a a ^ e e f			
S) a ^			
		OE d: P a j ) ^ * A x & @ a (	
Elektronische Bausätze		U n e j ) e t ^ U n i q @ i a	U n e j ) e t ^ F G
O n j ^ a e @ i c		O i a i ^ U n e j ) e t ^ i i	

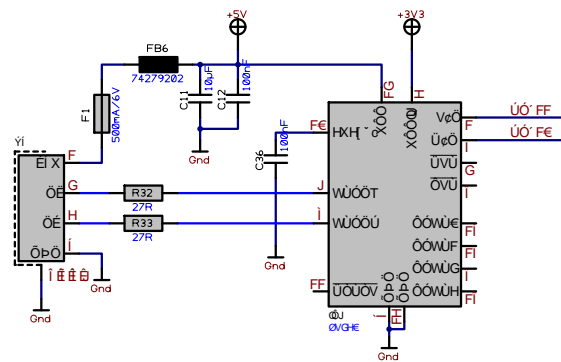
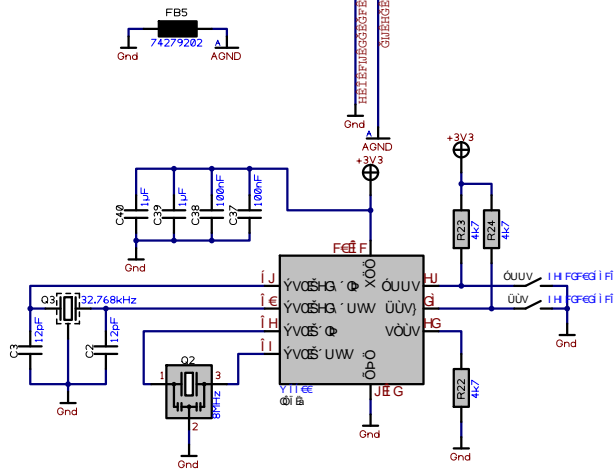
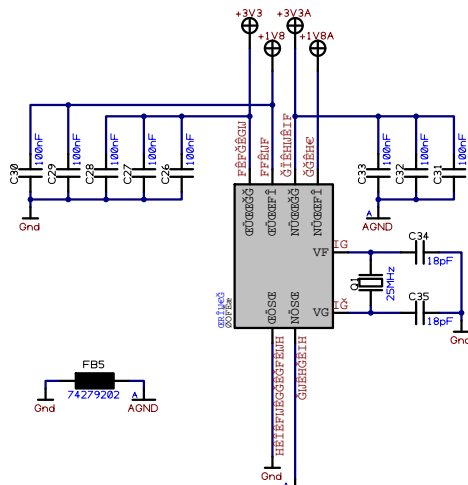
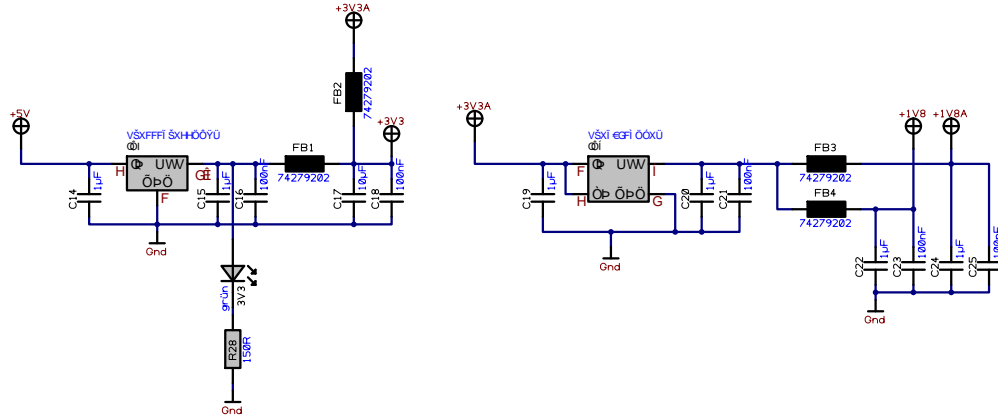

Uj'enc  
Y Qj^dy i i eebaa^a[ aá' eef

S'j^a^  
**eHaJo**  
Elektronische Bausätze

Uj'enc  
Paj^A^A^&@a[  
Uj'enc^  
Uj'enc^

Uj'enc^B^E  
FG

Uj'enc^

Uj'enc^d)